

APPLICARE ETICHETTE NUMERI SUI CONTATTI DOPPI

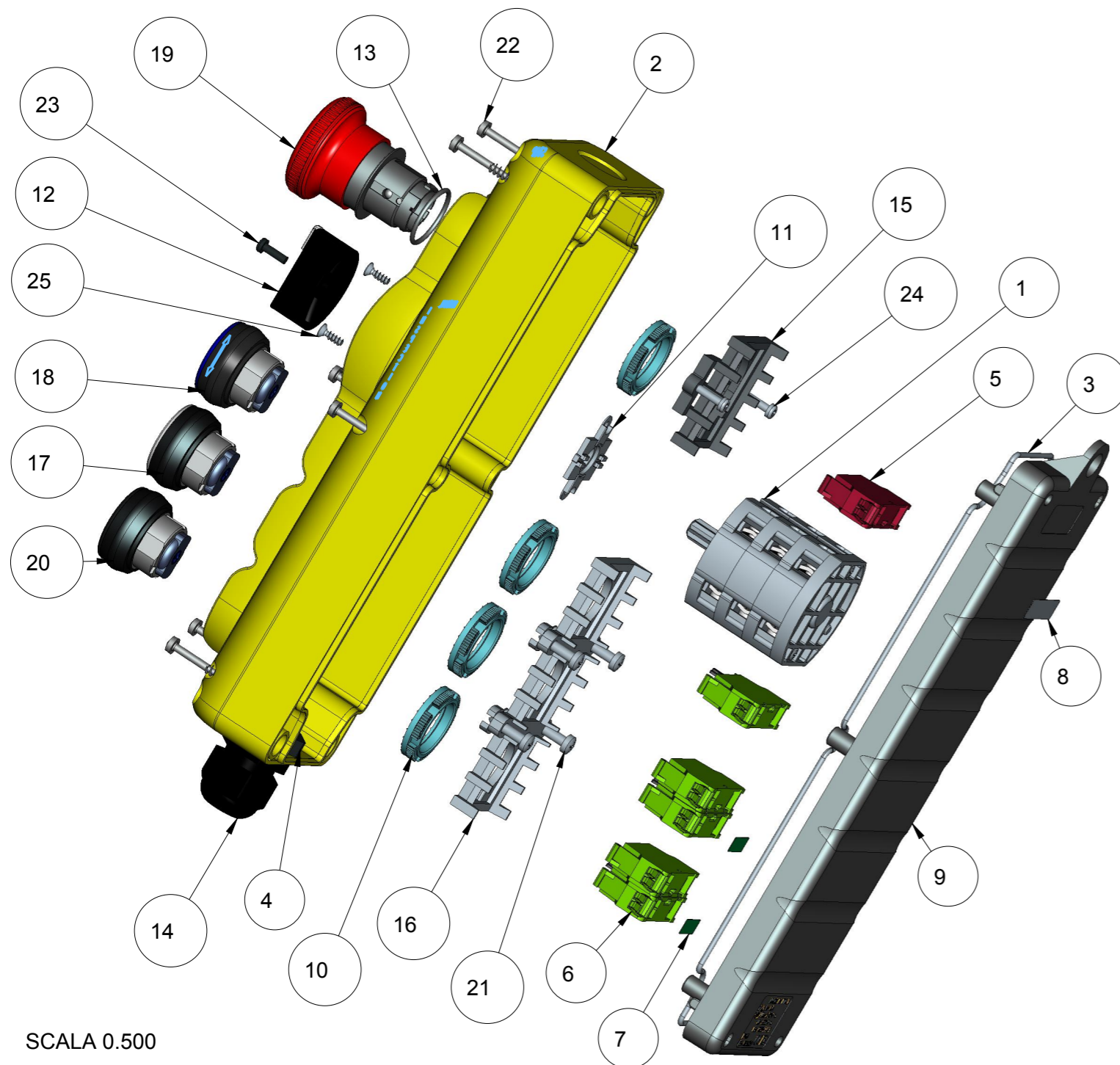

Cartiglio Rev. 01



SCALA 0.500

25	VITE TS TC 3X9 SCREWPLAST	--	11606043	2
24	VITE TC 3X13 SCREW	CROSS RECESSED PAN HEAD SCREW	11607012	2
23	VITE TC +- SCREWPLAST NERA 3X9.5	CROSS RECESSED PAN HEAD TAPPING SCREW	11606025	1
22	VITE AUTOFIL 4x30 FIL PARZ 720	SELF TAPPING SCREW 4x30	11606022	6
21	VITE AUTOF TC CROCE 3.9 x 16	SELF TAPPING SCREW 3.9 x 16	11607019	4
20	TASTO NERO FRECCIA DISCESA	BLACK BUTTON DOWN ARROW	PL005386	1
19	TASTO FUNGO PUSH-PULL D40	PUSH-PULL DIAM.40 VD	PPFN1P4NH	1
18	TASTO BLU SIMBOLO CONSENSO	BLUE BOTTON WITH CONSENT SYMBOL	PL005085-COM	1
17	TASTO BIANCO FRECCIA SALITA	WHITE BUTTON UP ARROW	PL005385	1
16	SUPPORTO 9 FRUTTI 10A	COUPLING PLATE 3 HOLES	PL003002	1
15	SUPPORTO 4 FRUTTI 16A	4 SPRING CONTACT BLOCK SUPPORT	11705102	1
14	PRESSACAVO M20x1.5	CABLE CLAMP	12901035	1
13	O-RING 2081	O-RING 2081	11902034	1
12	MANOPOLA CMT D34 Q6 NERA CON INDICE	BLACK KNOB D34 Q6 WITH INDICATOR	20402020	1
11	GUARNIZIONE CMT-PE IP65	GASKET IP65 FOR PE CAM SWITCH	11706315	1
10	GHIERA FILETTATA M22x1 IN ZAMA	M22x1 ZAMA LOCK NUTS	11705100	4
9	FONDO TLP-5 PCB	--	11711048	1
8	ETICHETTA_PULS_TLP5	CODE LABEL	13202300	1
7	ETICHETTA VERDE X FRUTTO NO 7-8	GREEN LABEL N°7-8 FOR CONTACT BLOCK	13202066	2
6	ELEMENTO CONTATTO 1NO 16A MOLLA	SPRING 1 CONTACT BLOCK 1 NO	PCW10	5
5	ELEMENTO CONTATTO 1NC 16A MOLLA	SPRING CONTACT BLOCK 1 NC	PCW01	1
4	DADO M20x1.5	NUT M20x1.5	12901036	1
3	CORDA GOMMA Ø2	--	11901035	1
2	COPERCHIO TLP-5 CMT ECO TAMPOGRAFATO	PRINTED COVER TLP5	20102084	1
1	COMMUTATORE 3NO+3NC ECO	SWITCH 3NO+3NC ECO	PE162644S	1
POS	DESCRIZIONE	DESCRIPTION	CODICE / COD	Q.ty

EDIZIONE / EDITION	DATA / DATE	MOD. / MODIFIED	FIRMA / SIGNATURE	MODIFICA / MODIFICATION	PRESCRIZIONE DI ISPEZIONE / PRESCRIPTION OF INSPECTION	LIVELLO / LEVEL	AQL
01	24/04/2016	CACCIA C		VEDI R.D.M. N°3484 - MODIFICATO LAYOUT	Visivo / Visual	I	2.5
02	11/10/17	CAROZZI		SOSTITUITO CMT DA PE162065S A PE162644S MOD:069-2017 CHANGED CMT FROM PE162065S TO PE162644S MOD:069-2017	Quota critica / Critique Dimension	II	1
--	--	--		--	Altre quote / Other Dimensions	I	2.5

GIOVENZANA INTERNATIONAL B.V.
Strawinskylaan 1105
1077 XX Amsterdam - NL

FINITURA / FINISH

MATERIALE / MATERIAL

DENOMINAZIONE / DESCRIPTION					SCALA/SCALE	DATA/DATE																								
PULSANTIERA 5 TASTI SAL/DIS/RESET/FUNGO/COMM					0.333	18/04/2011																								
PENDANT STATION TLP5					DIS. / DESIGNER																									
					CACCIA C.																									
DIM. INGOMBRO L x H x P					AVANZAMENTO/STATUS																									
0.0 x 0.0 x 0.0					Esecutivo																									
PESO / WEIGHT (g)					APPROV. / APPROVED																									
1806626.827					CACCIA C.																									
STAMPO / MOULD N°					REVISION																									
--					02																									
FIGURE N°/CAVITY N°					DISEGNO / DRAWING N°																									
0					TLP5																									
Tolleranza / Tolerance					REVISION																									
Dimensioni Nominali / Nominal Dimensions					02																									
<table border="1"> <tr> <td>>0,5</td> <td>>6</td> <td>>30</td> <td>>120</td> <td>>315</td> <td>>1000</td> <td>>2000</td> <td>>4000</td> </tr> <tr> <td>...6</td> <td>...30</td> <td>...120</td> <td>...315</td> <td>...1000</td> <td>...2000</td> <td>...4000</td> <td>...3,0</td> </tr> <tr> <td>±0,05</td> <td>±0,1</td> <td>±0,2</td> <td>±0,5</td> <td>±0,8</td> <td>±1,2</td> <td>±2,0</td> <td>±3,0</td> </tr> </table>					>0,5	>6	>30	>120	>315	>1000	>2000	>4000	...6	...30	...120	...315	...1000	...2000	...4000	...3,0	±0,05	±0,1	±0,2	±0,5	±0,8	±1,2	±2,0	±3,0		
>0,5	>6	>30	>120	>315	>1000	>2000	>4000																							
...6	...30	...120	...315	...1000	...2000	...4000	...3,0																							
±0,05	±0,1	±0,2	±0,5	±0,8	±1,2	±2,0	±3,0																							