

Contactors / Reversing-contactors  
 Contactores / Contactores-inversores  
 Contattori / Teleinvertitori  
 接触器 / 可逆接触器

Contacteurs / Contacteurs-inverseur  
 Schütze / Wendeschütze  
 Contatores / Contactores-inversores  
 КОНТАКТОРЫ / РЕВЕРСИВНЫЕ КОНТАКТОРЫ

~  
 LC1D40  
 LC1D50  
 LC1D65  
 LC1D80  
 LC1D95

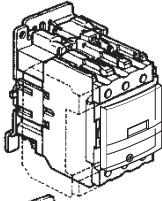

LC2D40  
 LC2D50  
 LC2D65  
 LC2D80  
 LC2D95

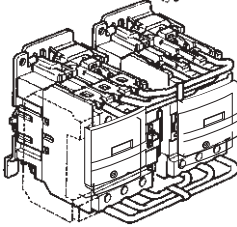

---  
 ---

LC1D40  
 LC1D50  
 LC1D65  
 LC1D80  
 LC1D95

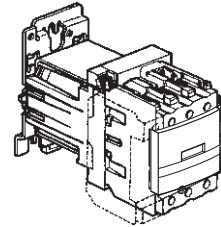

"For motor starting use Schneider Electric TeSys Protect - Deca overload relays"  
 "Pour les démarrages moteur, utilisez les relais contre les surcharges TeSys Protect - Deca de Schneider Electric"  
 "Para el arranque del motor, utilice relés de sobrecarga Schneider Electric TeSys Protect - Deca"  
 „Verwenden Sie für den Motorstart die Überlastrelais TeSys Protect - Deca von Schneider Electric.“  
 "Per l'avvio del motore utilizzare relè di sovraccarico Schneider Electric TeSys Protect - Deca"  
 "Para o arranque do motor, utilize Proteção TeSys Schneider Electric - relé de sobrecarga da Deca"  
 "电动机起动请使用施耐德电气TeSys保护Deca系列热过载继电器"  
 «Для запуска двигателя используйте реле для защиты от перегрузки Schneider Electric TeSys Protect - Deca»

## ⚠️ DANGER / DANGER / PELIGRO / GEFAHR / PERICOLO / PERIGO / 危险 / ОПАСНОСТЬ

**HAZARD OF ELECTRIC SHOCK, EXPLOSION OR ARC FLASH**  
 Disconnect all power before servicing equipment.  
**Failure to follow these instructions will result in death or serious injury.**

**RISQUE D'ÉLECTROCUTION, D'EXPLOSION OU D'ÉCLAIR D'ARC ÉLECTRIQUE**  
 Coupez toutes les alimentations avant de travailler sur cet appareil.  
**Si ces directives ne sont pas respectées, cela entraînera la mort ou des blessures graves.**

**PELIGRO DE DESCARGA ELÉCTRICA, EXPLOSIÓN O ARCO ELÉCTRICO**  
 Desconecte todas las alimentaciones antes de manipular el producto.  
**El incumplimiento de estas instrucciones podrá causar la muerte o lesiones serias.**

**GEFAHR VON ELEKTRISCHEM SCHLAG, EXPLOSION ODER LICHTBOGEN**  
 Vor dem Arbeiten am Gerät alle Spannungsversorgungen abschalten.  
**Die Nichtbeachtung dieser Anweisungen führt zu Tod oder schweren Verletzungen.**

**RISCHIO DI SCARICA ELETTRICA, ESPLOSIONE O ARCO ELETTRICO**  
 Scollegare l'apparecchio da tutti i circuiti di alimentazione prima di qualsiasi intervento.  
**Il mancato rispetto di queste istruzioni provocherà morte o gravi infortuni.**

**RISCO DE ELECTROCUSSÃO, DE EXPLOSIÃO, OU DE ARCO ELÉCTRICO**  
 Desconecte todas as alimentações antes de manipular o produto.  
**A não observância destas instruções resultará em morte, ou ferimentos graves.**

**电击、爆炸或电弧闪光危险**  
 在此电力设备上进行工作时,请先切断 所有电源。  
**不遵循上述说明将导致人员伤亡。**

**Опасность поражения электрическим током, опасность взрыва или вспышки дуги.**  
 Перед обслуживанием или ремонтом убедитесь, что питание отключено.  
**Несоблюдение этих инструкций приведет к смерти или серьезной травме.**



# WARNING / AVERTISSEMENT / ADVERTENCIA / WARNUNG / AVVERTIMENTO / ATENÇÃO / 警告 / ПРЕДУПРЕЖДЕНИЕ

## RISK OF FIRE OR ELECTRIC SHOCK (FOR CONTACTOR WITH UL HI-FAULT SHORT CIRCUIT CURRENT RATINGS ONLY)

- The opening of the branch-circuit protective device may be an indication that a fault current has been interrupted.
  - To reduce the risk of fire or electric shock, current-carrying parts and the other components of the controller should be examined and replaced if damaged.
- Failure to follow these instructions can result in death, serious injury, or equipment damage.**

## RISQUE D'INCENDIE OU D'ELECTROCUTION (POUR LES CONTACTEURS AYANT DES COURANTS DE COURT-CIRCUIT ASSIGNES UL TRES ELEVES UNIQUEMENT)

- L'ouverture du dispositif de protection de circuit de dérivation peut signaler qu'un courant en défaut a été interrompu.
  - Pour réduire le risque d'incendie ou d'électrocution, il convient d'examiner les composants porteurs de courant et les autres composants du contrôleur et de les remplacer s'ils sont endommagés.
- Si ces directives ne sont pas respectées, cela peut entraîner la mort ou des blessures graves ou des dommages matériels.**

## RIESGO DE INCENDIO O ELECTROCUCIÓN (SOLO PARA EL CONTACTOR CON CORRIENTES DE CORTOCIRCUITO ASIGNADAS UL MUY ELEVADAS)

- La apertura del dispositivo protector del circuito de derivación puede indicar que se ha interrumpido una corriente de defecto.
  - Para reducir el riesgo de incendio o electrocución, es necesario examinar las piezas que transporten corriente y otros componentes del controlador y sustituirlos en caso de que estén dañados.
- El incumplimiento de estas instrucciones puede causar la muerte, lesiones serias o daño al equipo.**

## BRAND- ODER STROMSCHLAGGEFAHR (NUR BEI SCHÜTZEN MIT KURZSCHLUSSFESTIGKEIT BEI HOHEM FEHLERSTROM NACH UL-STANDARD)

- Das Öffnen der Schutzvorrichtung für Abzweigleitungen kann ein Hinweis darauf sein, dass ein Fehlerstrom unterbrochen wurde.
  - Um die Brand- oder Stromschlaggefahr zu mindern, sollten stromführende Teile sowie die anderen Komponenten der Steuerung geprüft und bei Beschädigung ausgewechselt werden.
- Die Nichtbeachtung dieser Anweisungen kann Tod, schwere Verletzungen oder Sachschäden zur Folge haben.**

## RISCHIO DI INCENDIO O SCARICA ELETTRICA (SOLO PER CONTATTORE CERTIFICATO UL CON SCCL AD ALTA CORRENTE DI GUASTO)

- L'apertura del dispositivo di protezione del circuito di derivazione può indicare l'interruzione di una corrente di guasto.
- Per ridurre il rischio di incendio o scossa elettrica, esaminare e sostituire se danneggiate le parti sotto tensione e gli altri componenti.

**Il mancato rispetto di queste istruzioni può provocare morte, gravi infortuni o danni alle apparecchiature.**

## RISCO DE INCÊNDIO OU ELETROCUSSÃO (APENAS PARA CONTADORES COM ALTO VALOR NOMINAL DE CORRENTE DE CURTO-CIRCUITO DE FALHA)

- A abertura do dispositivo de proteção do circuito derivado pode ser uma indicação de que uma corrente de falha foi interrompida.
- Para reduzir o risco de incêndio ou choque elétrico, as peças que transportam corrente e os outros componentes do controlador devem ser examinados e substituídos se danificados.

**A não observância destas instruções pode provocar a morte, ferimentos graves, ou danos no equipamento.**

## 有火灾或电弧灼伤危险 (仅当继电器发生超故障短路电流时)

- 支路保护设备断开, 可能表示故障电流已中断。
- 如要降低起火或触电风险, 应检查控制器的载流部件或其他部件, 如有损坏, 应予以更换。

**不遵循上述说明可能导致人员伤亡或设备损坏。**

## ОПАСНОСТЬ ВОЗНИКНОВЕНИЯ ПОЖАРА ИЛИ УДАРА ЭЛЕКТРИЧЕСКИМ ТОКОМ (ТОЛЬКО ДЛЯ КОНТАКТОРОВ С ВЫСОКИМ НОМИНАЛОМ ТОКА КОРОТКОГО ЗАМЫКАНИЯ СОГЛАСНО UL)

- Размыкание защитного устройства распределительной сети может указывать на прерывание тока замыкания.
- Для уменьшения риска пожара или поражения электрическим током необходимо осмотреть и при выявлении повреждений заменить токонесящие части и другие компоненты контроллера.

**Несоблюдение этих инструкций может привести к смерти, серьезной травме или повреждению оборудования.**

### LC1

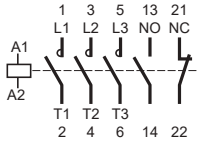

### LC2

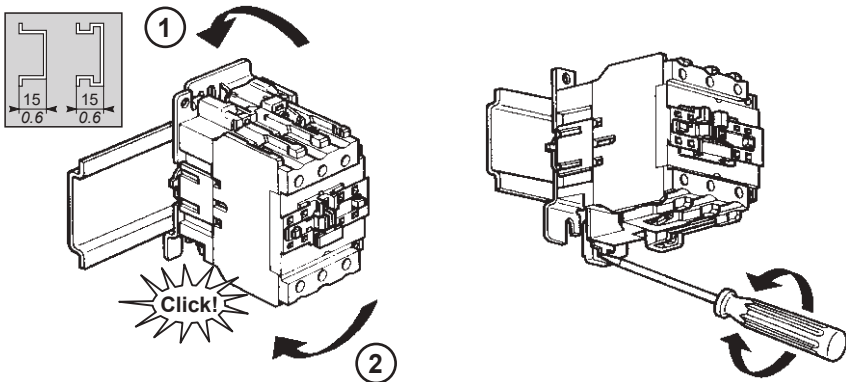
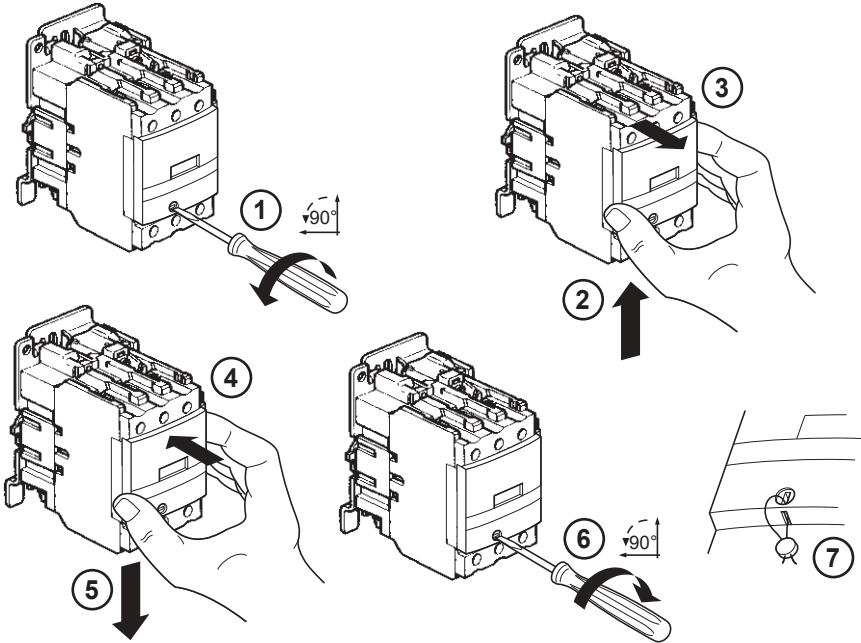
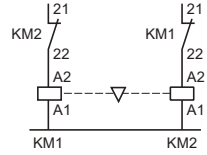
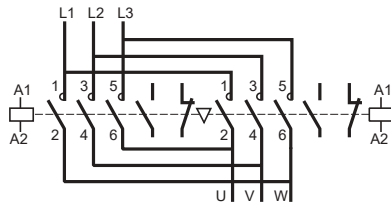

Adder blocks  
 Aditivos  
 Additivi  
 扩展模块

Additifs  
 Hilfsschalterblöcke aufrastbar  
 Aditivos  
 Блоки суммирования

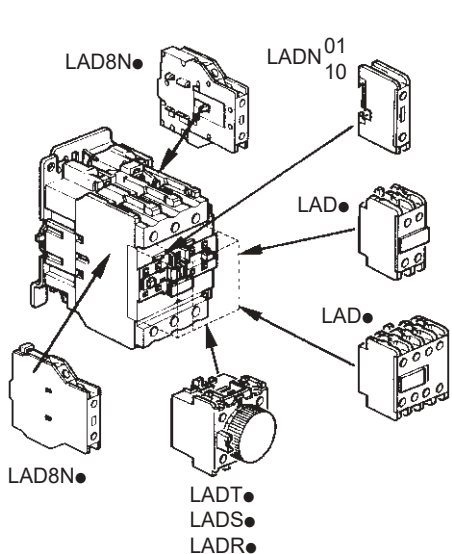

- |                       |                      |
|-----------------------|----------------------|
| 1 "F"                 | LADN10               |
| 1 "O"                 | LADN01               |
| 1 "F" + 1 "O"         | LADN11               |
| 2 "F"                 | LADN20               |
| 2 "O"                 | LADN02               |
| 2 "F" + 2 "O"         | LADN22               |
| 1 "F" + 3 "O"         | LADN13               |
| 4 "F"                 | LADN40               |
| 4 "O"                 | LADN04               |
| 3 "F" + 1 "O"         | LADN31               |
| 2 "F" + 2 "O"         | LADC22               |
|                       |                      |
| 2 "F"                 | LA1DX20 (See page 8) |
| 2 "F" + 2 "F"         | LA1DZ40 (See page 8) |
| 1 "F" + 1 "O" + 2 "F" | LA1DZ31 (See page 8) |
| 2 "F"                 | LA1DY20 (See page 8) |
|                       |                      |
| 0,1...3 s             | LADT0                |
| 0,1...30 s            | LADT2                |
| 1...30 s              | LADS2                |
| 10...180 s            | LADT4                |
|                       |                      |
| 0,1...3 s             | LADR0                |
| 0,1...30 s            | LADR2                |
| 10...180 s            | LADR4                |
|                       |                      |
| 1 "F" + 1 "O"         | LAD8N11 (See page 9) |
| 2 "F"                 | LAD8N20 (See page 9) |

LADN●  
 LADT●  
 LADR●

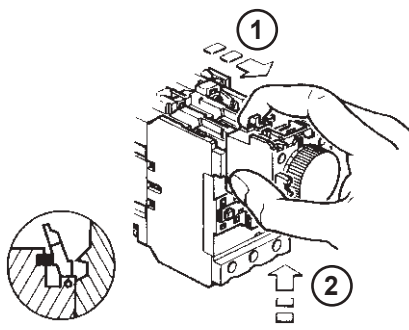
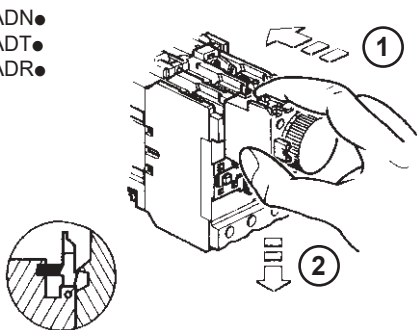

LADN<sup>01</sup><sub>10</sub>

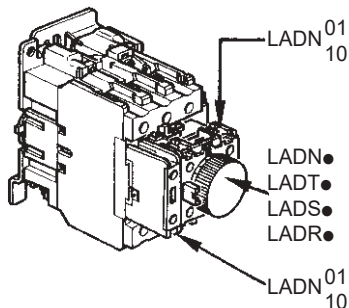
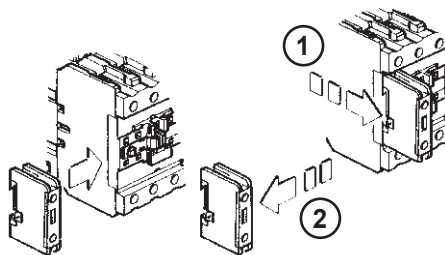

Dimensions/coils  
Dimensiones/bobinas  
Dimensioni d'incombro/bobine  
尺寸/线圈

Encombremets/bobines  
Abmessungen/Spulen  
Atravancamentos/bobinas  
Габариты/катушки

LC1D40...D95

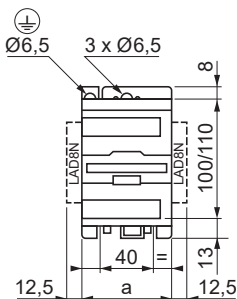

LC2D40...D95

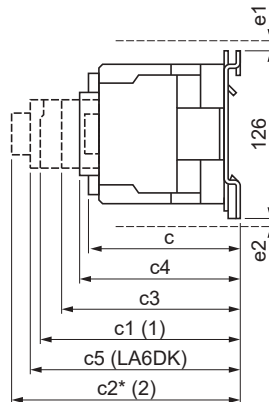
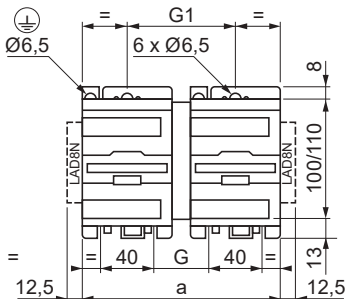

(mm)	3P a
LC1D40...D65	75
LC1D80...D95	85
LC2D40...D65	165
LC2D80...D95	182

(mm)	3P				
	e1	e2	c3	G	G1
LC2D40...D65	5	11	142	50	90
LC2D80...D95	13	20	158	57	96

(mm)	3P				
	c	c4	c1	c5	c2*
~ LC•D40...D65	114	116	146	157	165
~ LC•D80...D95	125	127	153	165	176
--- LC1D40...D65	171	173	202	213	221
--- LC1D80...D95	181	183	210	221	229

(1) LADN, LADC  
(2) LADR, LADT, LADS

\* + 4 mm (LA9D901)  
1 inch = 25,4 mm

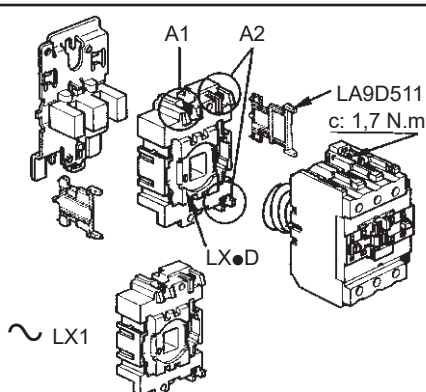
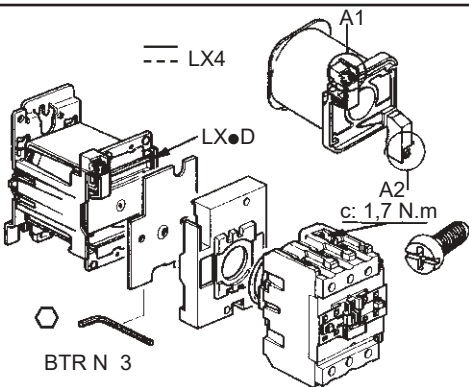

Operating positions  
Posiciones de funcionamiento  
Posizioni di funzionamento  
操作位置

Positions de fonctionnement  
Befestigungslage  
Posições de funcionamento  
Рабочие положения

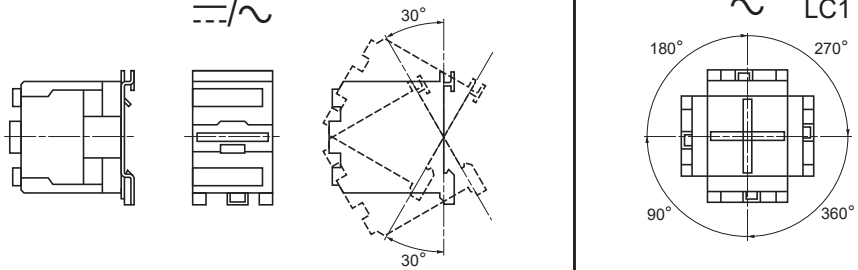

Wiring Min ... Max  
Raccordement Mini ... Maxi  
Capacidad de conexión Min ... Max  
Anschlüsse Min ... Max  
Connessione Min ... Max  
Ligação Min ... Máx  
接线最小 ... 最大  
Проводка Мин...макс

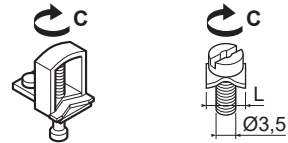

	LC1	LC2													
	(mm <sup>2</sup> )	(mm <sup>2</sup> )	(mm <sup>2</sup> )	(mm <sup>2</sup> )	(mm <sup>2</sup> )	(mm <sup>2</sup> )	(mm <sup>2</sup> )	L (mm)	(mm)		L (mm)		PH2/PZ2	C N.m	
D40	1...2,5	1...2,5 + 1...2,5	1...4	1...4 + 1...4	1...4	1...4 + 1...4	8	8			7,5	Ø 6	2	1,2	
D50	2,5 : 25	2,5...10 + 2,5...10	2,5 : 25	2,5...16 + 2,5...16	2,5 : 25	2,5...16 + 2,5...16	16			-	Ø 6	Ø 8		5	
D65															
D80	1...2,5	1...2,5 + 1...2,5	1...4	1...4 + 1...4	1...4	1...4 + 1...4	8	8			7,5	Ø 6	2	1,2	
D95	4 : 50	4...16 + 4...16	4 : 50	4...25 + 4...25	4 : 50	6...25 + 6...25	16	4			-	Ø 6	Ø 8	12*	
LXD	1...2,5	1...2,5 + 1...2,5	1...4	1...4 + 1...4	1...4	1...4 + 1...4	8	8			7,5	Ø 6	2	1,2	
LAD															

\* After installation due to creepage effect, it is recommended to recheck the torque periodically, especially for 35 mm<sup>2</sup> rigid cable or higher.  
\* 安装完成后, 考虑到金属蠕变效应, 建议定期检查扭矩, 尤其是对于 35 mm<sup>2</sup> 或更大的刚性电缆, 更应如此。

Drilling template  
Gabarit de perçage  
Guia de taladrado  
Bohrschablone  
Maschera di foratura  
Gabarito de furação  
钻孔模板  
Шаблон для сверления

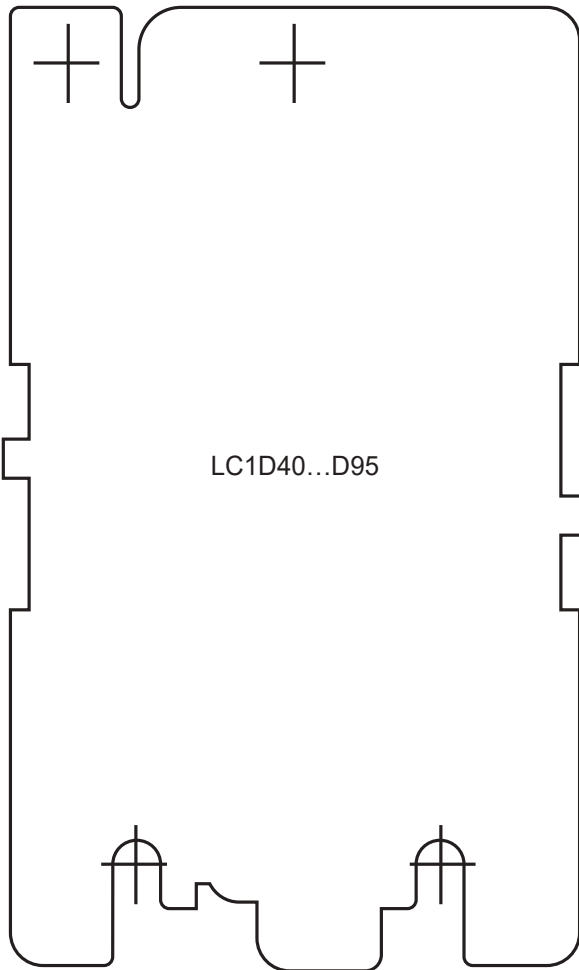

Others adder blocks  
 Los otros aditivos  
 Gli altri additivi  
 其他扩展模块

Les autres additifs  
 Hilfsschalterblöcke seitlicher Anbau  
 Os outros aditivos  
 Другие блоки суммирования

• **LA1DX●●, LA1DY●●, LA1DZ●●**

Environnement pollution  
 Environment pollutant  
 Ambiente polvoriento  
 Für verschmutzte Umgebung  
 Ambienti polverosi  
 Ambiente poluído  
 环境污染  
 Загрязнение окружающей среды

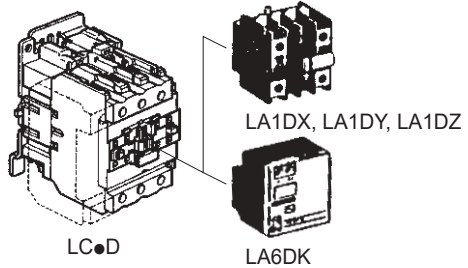

• **LA6DK**

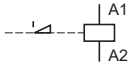

• **LA4DF, LA4DW, LA4DL**

Interface modules  
 Modules d'interface  
 Modulos interface  
 Interface - Module  
 Moduli d'interfaccia  
 Módulos de interface  
 接口模块  
 Интерфейсные модули

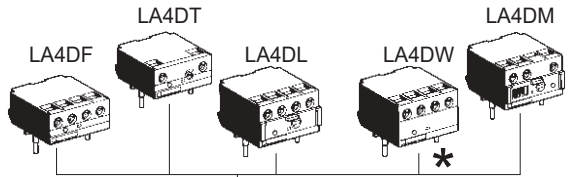

~~(\*) LC●D~~

• **LA4DM**

"Auto O Man"

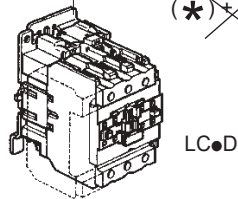

• **LA4DT**

Delay on coil energisation or desenergisation  
 Retard à l'excitation ou à la désexcitation bobine  
 Retraso a la conexión o a la desconexión de la bobina  
 Verzögerungsblöcke Ansprech, Rückfallver-zögert  
 Ritardo all'eccitazione o alla diseccitazione bobina  
 Atraso á excitação ou á desexcitação da bobina  
 线圈通电或断电延迟  
 Задержка возбуждения или снятия возбуждения катушки

• **LA4DA●, LA4DB●, LA4DC●, LA4DE●**

Coil suppressor  
 Antiparasites  
 Antiparasitarios  
 Überspannungsbegrenzer  
 Antiparassiti  
 Antiparasitas  
 线圈抑制器  
 Устройство защиты от перегрузок катушки

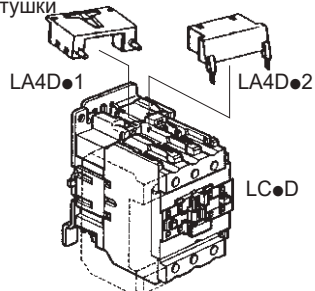



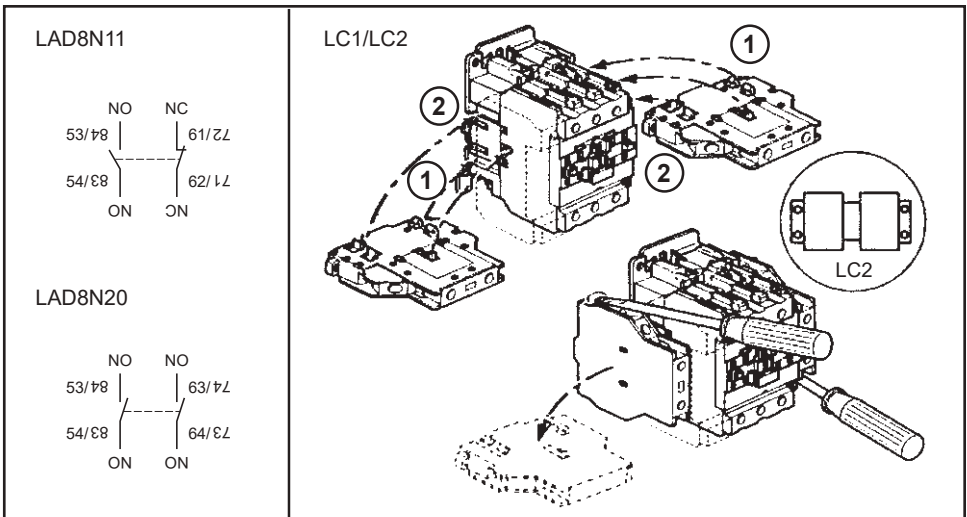

LC1/LC2	 Un	LADN● LADT● LADR● LA6DK●	LAD8N			
LC1 D40...D95	—	0,8...1,1	●			
LC1 D40...D95	~ 50-60 Hz	0,8...1,1	●			
		0,85...1,1	●	●	●	●
LC2 D40...D95	50 Hz	0,8...1,1	●	●	●	●
	60 Hz	0,8...1,1	●	●	●	●

3P AC TeSys Deca contactors (LC1D40 -> LC1D95) are grade 2 according to GB 21518. Maximum power consumption lower than 36.6 VA.  
 根据GB 21518标准, 三级 TeSys Deca系列交流接触器 (LC1D40 -> LC1D95) 能效等级为2级, 产品最大吸持功率低于36.6 VA

产品中有毒有害物质或元素的名称及含量 / Contents of Toxic or Hazardous Substances or Elements

部件名称 Part Name	有毒有害物质或元素 / Toxic or hazardous Substances and Elements					
	铅 (Pb)	汞 (Hg)	镉 (Cd)	六价铬 (Cr <sup>6+</sup> )	多溴联苯 (PBB)	多溴二苯醚 (PBDE)
金属部件 Metal Parts	X	O	O	O	O	O

**O** : 表示该有毒有害物质在该部件所有均质材料中的含量均在SJ/T11363-2006 标准规定的限量要求以下。  
 Indicates that this toxic or hazardous substance contained in all of the homogeneous materials for this part is below the limit requirement in SJ/T11363-2006.

**X** : 表示该有毒有害物质至少在该部件的某一均质材料中的含量超出SJ/T11363-2006 标准规定的限量要求。  
 Indicates that this toxic or hazardous substance contained in at least one of the homogeneous materials used for this part is above the limit requirement in SJ/T11363-2006.

对销售之日的所售产品, 本表显示, 施耐德电气供应链的电子产品信息可能包含这些物质。注意: 在所售产品中可能会也可能不会含有所有列出的部件。  
 Note: The products on sale may or may not contain all the parts/components listed here.



<p>The product's manufacture date is coded PPYYWWD, where:</p> <ul style="list-style-type: none"> <li>● PP: plant code</li> <li>● YY: year of manufacture</li> <li>● WW: week of manufacture</li> <li>● (D: weekday of manufacture (Monday = 1))</li> </ul>	<p>La date de fabrication du produit est codée PPYYWWD, avec:</p> <ul style="list-style-type: none"> <li>● PP: code usine</li> <li>● YY: année de fabrication</li> <li>● WW: semaine de fabrication</li> <li>● (D: jour de fabrication dans la semaine (lundi = 1))</li> </ul>	<p>La fecha de fabricación del producto está codificada PPYYWWD, donde:</p> <ul style="list-style-type: none"> <li>● PP: código de la planta</li> <li>● YY: año de fabricación</li> <li>● WW: semana de fabricación</li> <li>● (D: día de la semana de fabricación (lunes = 1))</li> </ul>	<p>Das Herstellungsdatum des Produkts ist folgendermaßen codiert: PPYYWWD. Wobei:</p> <ul style="list-style-type: none"> <li>● PP: Werkscode</li> <li>● YY: Herstellungsjahr</li> <li>● WW: Herstellungswoche</li> <li>● (D: Herstellungstag (Montag = 1))</li> </ul>
<p>La data di fabbricazione del prodotto è indicata con il codice PPYYWWD, dove:</p> <ul style="list-style-type: none"> <li>● PP: codice stabilimento</li> <li>● YY: anno di fabbricazione</li> <li>● WW: settimana di fabbricazione</li> <li>● (D: giorno della settimana in cui il prodotto è stato fabbricato (lunedì = 1))</li> </ul>	<p>A data de fabrico do produto está sob a forma de código PPYYWWD, onde:</p> <ul style="list-style-type: none"> <li>● PP: código da fábrica</li> <li>● YY: ano de fabrico</li> <li>● WW: semana de fabrico</li> <li>● (D: dia da semana de fabrico (Segunda-feira = 1))</li> </ul>	<p>产品制造日期采用如下代码 PPYYWWD, 其中:</p> <ul style="list-style-type: none"> <li>● PP: 工厂代码</li> <li>● YY: 制造年份</li> <li>● WW: 第几周制造</li> <li>● (D: 星期几制造 (星期一 = 1) )</li> </ul>	<p>Дата производства продукта закодирована в формате PPYYWWD, где:</p> <ul style="list-style-type: none"> <li>● PP: код завода</li> <li>● YY: год производства</li> <li>● WW: неделя производства</li> <li>● (D: день недели, когда был произведен продукт (понедельник = 1))</li> </ul>



**Schneider Electric Industries SAS**  
35, rue Joseph Monier  
CS30323  
F - 92500 Rueil-Malmaison  
[www.se.com](http://www.se.com)

**Schneider Electric Limited**

Stafford Park 5  
Telford, TF3 3BL  
United Kingdom  
[www.se.com/uk](http://www.se.com/uk)



**Уполномоченный поставщик в РФ:  
АО «Шнейдер Электрик»**

Адрес:  
127018, г. Москва, ул. Двинцев, д.12, корп.1,  
тел. +7 (495)777 99 88,  
факс: +7 (495)777 99 94, 8-800-200-6446  
[www.se.com/ru](http://www.se.com/ru)

